

▼ ZU4204TE-Q (Pro Electric serie), ZU4204BE-Q (Classic Electric serie)



Z Tough, Dependable Innovative CLASS



Classic Electrical

Basic electrical package includes mechanical contactor, ON/OFF toggle switch, pendant with electro-mechanical push buttons, 24V transformer timer and operator accessible circuit breaker.



Pro-Series Pump Models

Back-lit LCD and Pressure Transducer featuring Auto-Cycle Technology.

- Features Z-Class high-efficiency pump design; higher oil flow and bypass pressure, cooler running and requires 18% less current draw than comparable pumps
- Powerful 1,25 kW universal electric motor provides high power-to-weight ratio and excellent low-voltage operating characteristics
- High-strength, molded composite shroud protects motor and electrical components, while providing an ergonomic, non-conductive handle for easy transport
- Pendant provides additional safety for the operator.

Pro Series pumps only

- LCD readout provides pressure display and a number of diagnostic and readout capabilities never before offered on a portable electric pump
- Auto-Cycle feature provides continuous cycle operation of the torque wrench as long as the advance button is pressed (pump can be used with or without auto cycle).

- Digital read-out and "Autocycle" setting
- Display pressure (bar, MPa, psi) or torque (Nm, Ft.lbs) read-out
- Torque wrench model is selectable
- Pump usage information, hour and cycle counts
- Low-voltage warning and recording
- Self-test and diagnostic capabilities
- Information can be displayed in English, French, German, Italian, Spanish and Portuguese
- Pressure transducer is more accurate and durable than analog gauges
- Easy-viewing variable rate display.



◀ Any brand of hydraulic torque wrench can be powered by the portable ZU4T-Series torque wrench pump.

ZU4T-Series, Torque Wrench Pumps



Z-Class – A Pump For Every Application

Patented Z-Class pump technology provides high by-pass pressures for increased productivity – important in applications using long hose runs and high pressure-drop circuits, like heavy lifting or certain double-acting tools. Enerpac ZU4T-Series pumps are built to power small to large torque wrenches. Choosing the right ZU4T-Series torque wrench pump for your application is easy.

Classic Electric Torque Wrench Pumps

- The Classic has traditional electro-mechanical components (transformers, relays and switches) in place of solid-state electronics. The Classic delivers durable, safe and efficient hydraulic power.

Pro Series Electric Torque Wrench Pump

- Digital (LCD) display features a built-in hour meter, pressure display and shows self-diagnostic, cycle-count and low voltage warning information. These premium features are not available on any other pump – anywhere!
- Auto-Cycle feature provides continuous cycle operation of the torque wrench as long as the advance button is pressed (pump can be used with or without Auto-Cycle feature).

ZU4T Series



Reservoir Capacity:

4,0 - 8,0 litres

Flow at Rated Pressure:

1,0 l/min

Motor Size:

1,25 kW

Maximum Operating Pressure:

700 - 800 bar



Torque Wrench Pump Selection

For optimum speed and performance see the torque wrench pump and hose selection matrix.

Page: **40**

OIL FLOW VERSUS PRESSURE

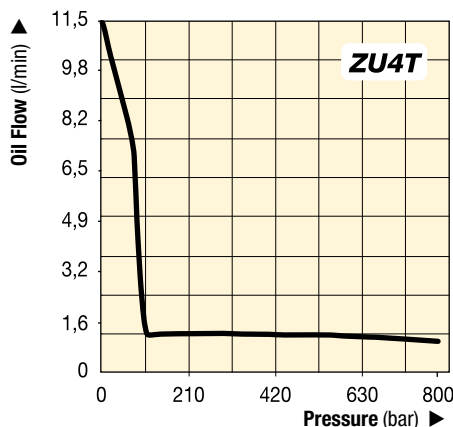

COMMON PUMP MODELS

For Use With Torque Wrenches	Model Number ^{1) 4)}	Motor Electrical Specification	Usable Oil Capacity (litres)	(kg)
Pro Series pumps All wrenches	ZU4204TB-Q	115 VAC, 1-ph	4,0	32
	ZU4208TB-Q	115 VAC, 1-ph	8,0	34
	ZU4204TE-Q ²⁾	208-240 VAC, 1-ph	4,0	32
	ZU4208TE-Q ²⁾	208-240 VAC, 1-ph	8,0	34
	ZU4204TI-Q ³⁾	208-240 VAC, 1-ph	4,0	32
	ZU4208TI-Q ³⁾	208-240 VAC, 1-ph	8,0	34
Classic pumps All wrenches	ZU4204BB-QH	115 VAC, 1-ph	4,0	37
	ZU4204BB-Q	115 VAC, 1-ph	4,0	33
	ZU4208BE-QH ²⁾	208-240 VAC, 1-ph	8,0	38
	ZU4204BE-Q ²⁾	208-240 VAC, 1-ph	4,0	34
	ZU4208BI-QH ³⁾	208-240 VAC, 1-ph	8,0	40
	ZU4208BI-Q ³⁾	208-240 VAC, 1-ph	8,0	36



Pump Ratings

-Q suffix pumps are for **700 bar** torque wrenches, and include spin-on couplers.

-E suffix pumps are for use with Enerpac SQD and HXD-Series **800 bar** torque wrenches, and include polarized lock-ring safety couplers.

Page: **44**



Gauge and Overlay Kit

Available separately for use with ZU4T-Series Classic:

GT-4015Q includes gauge and overlays for all S- and W-Series

torque wrenches.

GT-4015 includes gauge and overlays for all SQD and HXD torque wrenches.

¹⁾ All models meet CE safety requirements and all CSA requirements.

²⁾ European plug and CE EMC directive compliant

³⁾ With NEMA 6-15 plug

⁴⁾ Select -E suffixed pumps for Enerpac SQD and HXD-Series 800 bar torque wrenches, see page 44.

▼ This is how a ZU4T-Series pump model number is built up:



1 Product Type

Z = Pump series

2 Motor Type

U = Universal electric motor

3 Flow Group

4 = 1,0 l/min @ 700 bar

4 Valve Type

2 = Torque wrench valve

5 Reservoir Size

04 = 4,0 litres usable oil

08 = 8,0 litres usable oil

6 Valve Operation

T = **Pro Electric Serie pump** with solenoid valve and pendant, LCD Electric and pressur transducer

B = **Classic Electric pump** with solenoid valve and pendant.

7 Voltage

B = 115V, 1 ph, 50/60 Hz

E = 208-240V, 1 ph, 50/60 Hz (with European plug CE RF compliant)

I = 208-240V, 1 ph, 50/60 Hz (with NEMA 6-15 plug)

8 Options

E = **with 800 bar coupler** for use with HXD and SQD-Series or other wrenches

Q = **with 700 bar coupler** for use with S and W-Series or other wrenches

H = Heat exchanger

K = Skid bar

M = 4-wrench manifold

R = Roll cage



How to order your ZU4T-Series torque wrench pump

Ordering Example

Model No. **ZU4208TE-QMHM**

700 bar Pro Electric Series pump for use with Enerpac S and W-Series and other 700 bar torque wrenches, 230V motor, 8 litres reservoir, 4-wrench manifold, heat exchanger and skidbar.

Refer to the torque wrench pump selection matrix for optimum wrench, pump and hose combinations.

Page: **40**

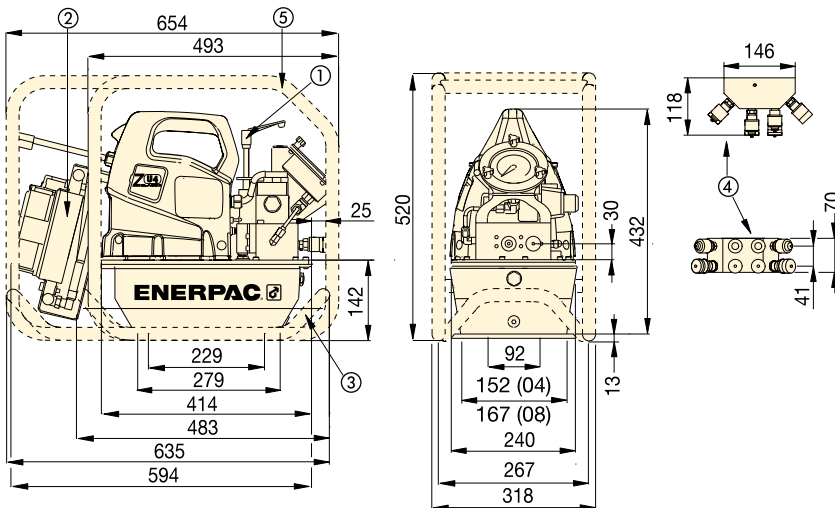

ZU4T-Series Torque Wrench Pumps

- ① User adjustable relief valve
- ② Heat Exchanger (optional)
- ③ Skidbar (optional)
- ④ 4-wrench manifold (optional)
- ⑤ Roll cage (optional)



Torque Wrench Hoses

Use Enerpac twin safety hoses to connect your torque wrench to the pump.

For 700 bar	Model Nr.
6 m long, 2 hoses	THQ-706T
12 m long, 2 hoses	THQ-712T
For 800 bar	
6 m long, 2 hoses	THC-7062
12 m long, 2 hoses	THC-7122

ZU4T-Series Performance Chart							
Motor Size (kW)	Output Flow Rate (l/min)				Motor Electrical Specification (Volt - Phase - Hz)	Sound Level (dBA)	Relief Valve Adjustment Range (bar)
	7 bar	50 bar	350 bar	700 bar			
1,25	11,5	8,8	1,2	1,0	115 - 1 - 50/60 208-240 - 1 - 50/60	85-90	124-700 *

* Pump type (-Q) shown, (-E) range is 124-800 bar.

ZU4T-Series, Pump Options



Heat Exchanger

- Removes heat from the bypass oil to provide cooler operation
- Stabilizes oil viscosity, increasing oil life and reduces wear of pump and other hydraulic components.

Accessory Kit * Model Nr.	Can be used on ZU4-Series torque wrench pumps
ZHE-U115	115 Volt pumps
ZHE-U230	230 Volt pumps

* Add suffix **H** to pump model number for factory installation.

Heat Exchanger adds 4,1 kg to pump weight.

Ordering Example: **ZU4208TE-QH**



Skid Bar

- Provides greater pump stability on soft or uneven surfaces
- Provides easy two-handed lift.

Accessory Kit * Model Nr.	Can be used on ZU4-Series torque wrench pumps
SBZ-4	04 and 08 reservoir ¹⁾
SBZ-4L	04 and 08 reservoir ²⁾

* Add suffix **K** to pump model number for factory installation.

¹⁾ For pump without heat exchanger 2,2 kg.

²⁾ For pump with heat exchanger 3,2 kg.

Ordering Example: **ZU4208TE-QK**



Roll Cage

- Protects pump
- Provides greater pump stability.

Accessory Kit * Model Nr.	Can be used on ZU4-Series torque wrench pumps
ZRC-04	04 and 08 reservoir ¹⁾
ZRC-04H	04 and 08 reservoir ²⁾

* Add suffix **R** for factory installation.

¹⁾ For pump without heat exchanger 5 kg.

²⁾ For pump with heat exchanger 7 kg.

Ordering Example: **ZU4208TE-QR**



4-Wrench Manifold

- For simultaneous operation of multiple torque wrenches
- Can be factory installed or ordered separately.

Accessory Kit * Model Nr.	Can be used on ZU4-Series torque wrench pumps
ZTM-E	for 800 bar torque wrenches
ZTM-Q	for 700 bar torque wrenches

* Add suffix **M** for factory installation.

Weight 4,0 kg.

Ordering Example: **ZU4208TE-QM**

ZU4T Series



Reservoir Capacity:

4,0 - 8,0 litres

Flow at Rated Pressure:

1,0 l/min

Motor Size:

1,25 kW

Maximum Operating Pressure:

700 - 800 bar

▼ Most hydraulic torque wrenches can be powered by the Enerpac ZU4T-Series torque wrench pump.

